



30GX 082-358

30HXC 080-375

Liquid Chillers

Appendix - Option 61

(380 V-3 ph-60 Hz)

Nominal cooling capacity 30HXC: 284-1280 kW

Nominal cooling capacity 30GX: 276-1217 kW

60 Hz

GLOBAL CHILLER

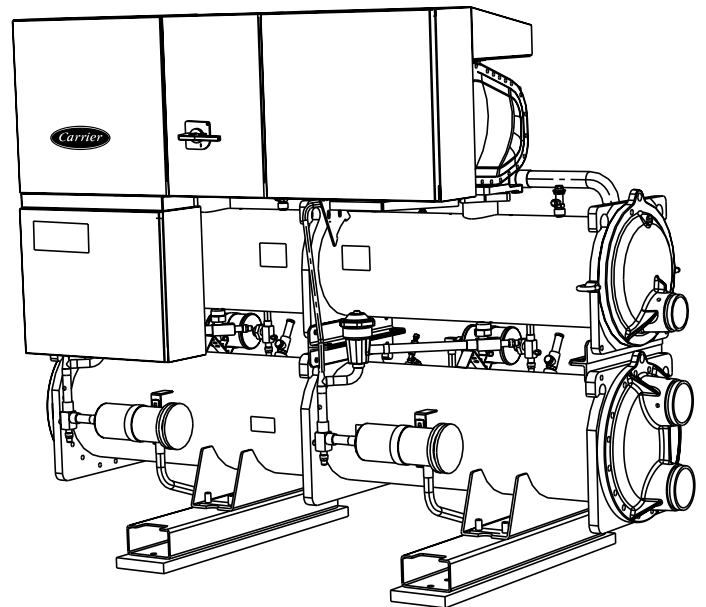
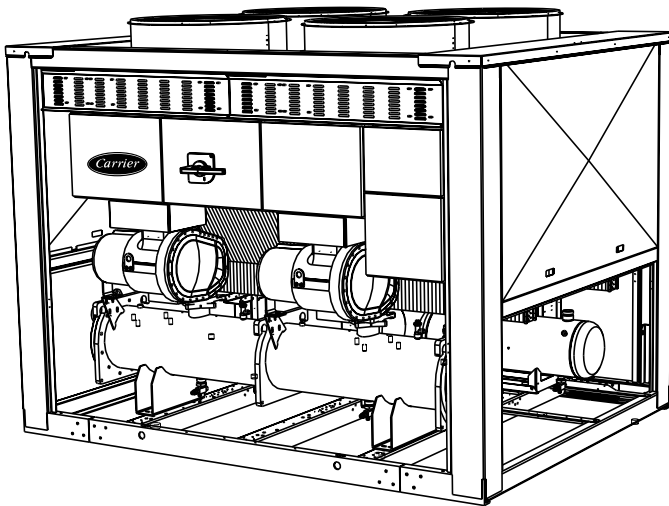

Installation, operation and maintenance instructions



Quality Management System Approval

The cover graphics is for illustrative purposes only and is not part of any offer for sale or contract.

LIST OF CONTENTS

	Page
5 - PHYSICAL AND ELECTRICAL DATA FOR 30HXC UNITS	4
5.1 - Physical data 30HXC	4
5.2 - Electrical data 30HXC	4
5.3 - Electrical data, 30HXC compressors	5
5.4 - Electrical data for units with high condensing temperatures (option 150/150A)	5
6 - PHYSICAL AND ELECTRICAL DATA FOR UNITS 30GX	7
6.1 - Physical data 30GX	7
6.2 - Electrical data 30GX	7
6.3 - Electrical data, 30GX and 30HXC compressors, option 150 + 150A	8
8 - ELECTRICAL CONNECTION	9
8.5 - Recommended wire sections	9

5 - PHYSICAL AND ELECTRICAL DATA FOR 30HXC UNITS

5.1 - Physical data 30HXC

30HXC		080	090	100	110	120	130	140	155	175	190	200	230	260	285	310	345	375	
Cooling capacity*	kW	284	309	339	371	415	446	505	537	593	639	701	806	889	963	1081	1185	1280	
Operating weight	kg	2274	2279	2302	2343	2615	2617	2702	2712	3083	3179	3873	4602	4656	4776	5477	5553	5721	
Refrigerant charge**	kg	HFC-134a																	
Circuit A**		33	33	32	31	49	51	48	54	54	70	92	115	117	132	109	96	119	
Circuit B**		34	34	30	35	52	47	48	57	50	70	58	63	75	80	106	109	137	
Oil		Polyolester oil CARRIER SPEC. PP 47-32																	
Circuit A	l	15	15	15	15	15	15	15	15	15	15	30	30	30	30	30	30	30	
Circuit B	l	15	15	15	15	15	15	15	15	15	15	15	15	15	15	30	30	30	
Compressors		Semi-hermetic, twin-screw POWER ³																	
Size - Circuit A***		39	46	46	56	56	66	80	80	80	80+	66/56	80/56	80/80	80+/80+	80/66	80/80	80+/80+	
Size - Circuit B***		39	39	46	46	56	56	56	66	80	80+	66	80	80	80+	80/66	80/80	80+/80+	
Capacity control		PRO-DIALOG Plus control																	
No. of control steps		6	6	6	6	6	6	6	6	6	6	8	8	8	8	10	10	10	
Minimum step capacity	%	19	19	21	19	21	19	17	19	21	21	14	14	14	14	10	10	10	
Evaporator		Shell and tube with internally finned copper tubes																	
Net water volume	l	50	50	58	69	65	65	75	75	88	88	126	155	170	170	191	208	208	
Water connections		Victaulic connections																	
Inlet/outlet	in	4	4	4	5	5	5	5	5	5	5	6	6	6	6	8	8	8	
Drain and vent (NPT)	in	3/8																	
Max. water side operating pressure	kPa	1000																	
Condenser		Shell and tube with internally finned copper tubes																	
Net water volume	l	48	48	48	48	78	78	90	90	108	108	141	190	190	190	255	255	255	
Water connections		Victaulic connections																	
Inlet/outlet	in	5	5	5	5	5	5	5	5	6	6	6	8	8	8	8	8	8	
Drain and vent (NPT)	in	3/8																	
Max. water side operating pressure	kPa	1000																	

* Based on standardised ARI conditions: Evaporator entering/leaving water temperature 12.2°C and 6.7°C. Condenser entering/leaving water temperature 29.6°C/35°C. Evaporator and condenser fouling factor = 0.00022 m² K/W.

** Not applicable to high condensing temperature units - please refer to electronic selection catalogue).

*** The weights shown are guidelines only. For the unit refrigerant charge please refer to the unit nameplate.

**** Nominal size per compressor. The compressor size is the same as its nominal cooling capacity in tons of refrigeration (1 ton = 3.517 kW).

5.2 - Electrical data 30HXC

30HXC		080	090	100	110	120	130	140	155	175	190	200	230	260	285	310	345	375	
Power circuit		V-ph-Hz 380-3-60																	
Nominal power supply*	V	342-418																	
Control circuit supply		The control circuit is supplied via the factory-installed transformer																	
Nominal operating power input*	kW	56	63	69	78	82	91	103	111	123	129	142	166	189	198	223	249	261	
Nominal operating current drawn*	A	114	123	132	146	161	178	198	215	235	257	276	315	352	386	430	469	515	
Max. operating power input**	kW	87	96	105	118	130	144	159	172	187	212	223	253	281	318	344	374	424	
Circuit A**	kW	-	-	-	-	-	-	-	-	-	-	144	159	187	212	172	187	212	
Circuit B**	kW	-	-	-	-	-	-	-	-	-	-	79	94	94	106	172	187	212	
Max. operating current drawn (Un - 10%)***	A	162	178	194	218	242	266	294	319	246	392	412	467	519	588	637	692	784	
Circuit A***	A	-	-	-	-	-	-	-	-	-	-	266	294	346	392	319	346	392	
Circuit B***	A	-	-	-	-	-	-	-	-	-	-	145	173	173	196	319	346	392	
Maximum operating current drawn (Un)***	A	148	162	177	198	220	242	267	290	315	356	374	424	472	534	580	630	712	
Circuit A***	A	-	-	-	-	-	-	-	-	-	-	242	267	315	356	290	315	356	
Circuit B***	A	-	-	-	-	-	-	-	-	-	-	132	157	157	178	290	315	356	
Maximum starting current, standard unit (Un)†	A	189	189	203	229	251	279	313	335	360	417	778	908	956	1113	1063	1113	1291	
Circuit A***	A	-	-	-	-	-	-	-	-	-	-	646	751	798	935	773	798	935	
Circuit B***	A	-	-	-	-	-	-	-	-	-	-	536	641	641	757	773	798	935	
Max. starting current/max. current draw ratio, unit		1.28	1.16	1.15	1.16	1.14	1.15	1.17	1.16	1.14	1.17	2.08	2.14	2.02	2.08	1.84	1.77	1.81	
Max. starting current/max. current draw ratio, circuit A		-	-	-	-	-	-	-	-	-	-	2.67	2.81	2.54	2.63	2.67	2.54	2.63	
Max. starting current/max. current draw ratio, circuit B		-	-	-	-	-	-	-	-	-	-	4.05	4.07	4.07	4.25	2.67	2.54	2.63	
Max. starting current - reduced current start (Un)‡	A	std.	std.	std.	std.	std.	std.	std.	std.	std.	std.	492	597	645	736	752	802	914	
Circuit A	A	std.	std.	std.	std.	std.	std.	std.	std.	std.	std.	360	440	487	558	462	487	558	
Circuit B	A	std.	std.	std.	std.	std.	std.	std.	std.	std.	std.	225	270	270	315	462	487	558	
Max. starting current - red. current start/max. current draw ratio, unit		std.	std.	std.	std.	std.	std.	std.	std.	std.	std.	1.31	1.41	1.37	1.38	1.30	1.27	1.28	
Circuit A		std.	std.	std.	std.	std.	std.	std.	std.	std.	std.	1.49	1.65	1.55	1.57	1.60	1.55	1.57	
Circuit B		std.	std.	std.	std.	std.	std.	std.	std.	std.	std.	1.70	1.72	1.72	1.77	1.60	1.55	1.57	
Three-phase short circuit holding current	kA	25	25	25	25	25	25	25	25	25	25	N/A	N/A	N/A	N/A	N/A	N/A	N/A	
Circuit A	kA	-	-	-	-	-	-	-	-	-	-	25	25	25	25	25	25	25	
Circuit B	kA	-	-	-	-	-	-	-	-	-	-	15	15	15	15	25	25	25	
Customer standby capacity, unit or circuit B, for evaporator water pump connections‡	kW	8	8	8	11	11	11	15	15	15	15	15	18	18	30	30	30	30	

* Based on standardised ARI conditions: Evaporator entering/leaving water temperature 12.2°C and 6.7°C. Condenser entering/leaving water temperature 29.6°C/35°C.

** Power input, compressor, at unit operating limits (evaporator water entering/leaving temperature = 15°C/10°C, condenser entering/leaving water temperature = 45°C/50°C) and a nominal voltage of 380 V (data given on the unit name plate).

*** Maximum unit operating current at maximum unit power input.

† Maximum instantaneous starting current (maximum operating current of the smallest compressor(s) + locked rotor current or reduced starting current of the largest compressor)

‡ Current and power inputs not included in the values above.

N/A Not applicable

5.3 - Electrical data, 30HXC compressors

Reference	Size	I nom.	MHA	LRA	LRA (Y)	LRA (S) 1 cp	LRA (S) 2 cp
06NW2123W6N	39	43	67	330	104	NA	NA
06NW2146W7N	46	49	80	330	104	NA	NA
06NW2174W7N	56	61	100	405	128	175	210
06NW2209W7N	66	73	120	485	153	205	250
06NW2250W7N	80	88	143	580	183	245	300
06NW2250W7E	80+	97	162	685	216	285	345

Legend:

- 06NW - Compressor for water-cooled units
- N - Non-economized compressor
- E - Economized compressor
- INOM - Average current draw of the compressor at ARI conditions
- MHA - Must hold amperes (maximum operating current) at 342 V
- LRA - Locked rotor current with across-the-line start
- LRA (Y) - Locked rotor current at reduced current (star/delta start-up mode)
- LRA (S) 1 cp. - Start-up with reduced current with electronic starter (start-up duration 3 seconds max.) for one compressor per circuit
- LRA (S) 2 cp. - Start-up with reduced current with electronic starter (start-up duration 3 seconds max.) for two compressors per circuit

5.4 - Electrical data for 30HXC units with high condensing temperatures (option 150/150A)

30HXC		080	090	100	110	120	130	140	155	175	190	200	230	260	285	310	345	375
Power circuit		The control circuit is supplied via the factory-installed transformer																
Nominal power supply (Un)	V-ph-Hz	380-3-60																
Voltage range	V	342-418																
Control circuit supply		The control circuit is supplied via the factory-installed transformer																
Max. operating power input*	kW	107	119	131	146	162	180	196	214	231	277	279	312	347	415	429	462	553
Circuit A	kW	-	-	-	-	-	-	-	-	-	-	180	196	231	277	214	231	277
Circuit B	kW	-	-	-	-	-	-	-	-	-	-	99	116	116	138	214	231	277
Max. operating current drawn (Un - 10%)**	A	203	225	246	275	304	337	367	400	431	517	522	582	646	776	800	862	1034
Circuit A	A	-	-	-	-	-	-	-	-	-	-	337	367	431	517	400	431	517
Circuit B	A	-	-	-	-	-	-	-	-	-	-	185	215	215	259	400	431	517
Maximum operating current drawn (Un)**	A	184	204	224	250	276	306	334	364	392	470	474	530	588	705	728	784	940
Circuit A	A	-	-	-	-	-	-	-	-	-	-	306	334	392	470	364	392	470
Circuit B	A	-	-	-	-	-	-	-	-	-	-	168	196	196	235	364	392	470
Maximum starting current, standard unit (Un)†	A	261	295	315	351	377	424	459	489	517	645	1212	1351	1409	1769	1549	1605	2004
Circuit A†	A	-	-	-	-	-	-	-	-	-	-	1044	1155	1213	1534	1185	1213	1534
Circuit B†	A	-	-	-	-	-	-	-	-	-	-	906	1017	1017	1299	1185	1213	1534
Max. starting current/max. current draw ratio, unit		1.42	1.45	1.41	1.40	1.37	1.39	1.37	1.34	1.32	1.37	2.56	2.55	2.40	2.51	2.13	2.05	2.13
Max. starting current/max. current draw ratio, circuit A		-	-	-	-	-	-	-	-	-	-	3.41	3.46	3.10	3.26	3.26	3.10	3.26
Max. starting current/max. current draw ratio, circuit B		-	-	-	-	-	-	-	-	-	-	5.39	5.19	5.19	5.53	3.26	3.10	3.26
Max. starting current - reduced current start (Un) †	A	std.	std.	std.	std.	std.	std.	std.	std.	std.	std.	756	844	902	1070	1042	1098	1305
Circuit A	A	std.	std.	std.	std.	std.	std.	std.	std.	std.	std.	588	648	706	835	678	706	835
Circuit B	A	std.	std.	std.	std.	std.	std.	std.	std.	std.	std.	320	360	360	450	678	706	835
Max. starting current - red. current start/max. current draw ratio, unit		std.	std.	std.	std.	std.	std.	std.	std.	std.	std.	1.59	1.59	1.53	1.52	1.43	1.40	1.39
Circuit A		std.	std.	std.	std.	std.	std.	std.	std.	std.	std.	1.92	1.94	1.80	1.78	1.86	1.80	1.78
Circuit B		std.	std.	std.	std.	std.	std.	std.	std.	std.	std.	1.90	1.84	1.84	1.91	1.86	1.80	1.78
Three-phase short circuit holding current	kA	25	25	25	25	25	25	25	25	25	25	N/A	N/A	N/A	N/A	N/A	N/A	N/A
Circuit A	kA	-	-	-	-	-	-	-	-	-	-	25	25	25	25	25	25	25
Circuit B	kA	-	-	-	-	-	-	-	-	-	-	15	15	15	15	25	25	25
Customer standby capacity, unit or circuit B, for evaporator water pump connections‡	kW	8	8	8	11	11	11	15	15	15	15	15	18	18	30	30	30	30

* Power input, compressor, at unit operating limits (evaporator water entering/leaving temperature = 15°C/10°C, condensing temperature = 68°C) and a nominal voltage of 380 V (data given on the unit name plate).

** Maximum unit operating current at maximum unit power input.

† Maximum instantaneous starting current (maximum operating current of the smallest compressor(s) + locked rotor current or reduced starting current of the largest compressor)

‡ Current and power inputs not included in the values above

N/A Not applicable

The 30HXC 080-375 units for high condensing temperatures are directly derived from the standard models. Their application range is the same as that of the standard units, but permits operation at condenser leaving water temperatures up to 63°C. The PRO-DIALOG control offers all the advantages of the standard units, plus control of the condenser leaving water temperature.

The main modifications are:

- Use of 30GX compressors (example: 06NA2300S5N instead of 06NW 2300S5N).
- Modification of electrical components to operate with compressors for high condensing temperatures.
- Modification of heat exchangers to meet pressure code requirements (if necessary).

Option 150

These units are designed for traditional applications for water-cooled units, but for higher condenser leaving water temperatures than 50°C.

Like the standard units they are equipped with condenser entering and leaving water sensors.

It is possible to control the machine at the condenser water outlet, requiring a factory configuration change and the use of a heating/cooling inlet reversing device.

Option 150A

These units are designed for water-to-water heat pumps.

They are factory configured as heat pumps (heating/cooling control as a function of the remote reversing device). The condenser incorporates thermal insulation that is identical to that of the evaporator.

Technical information

All information is identical to that of the standard 30HXC units, except for the following paragraphs.

Selection

There are no nominal conditions for this unit type. The selection is made using the current electronic catalogue.

Dimensions

These are identical to those of the standard 30HXC units. The only difference is in the diameter of the incoming field wiring connection, described in the chapter "Recommended selection". Refer to the dimensional drawings for these units, before proceeding with the wiring.

Compressor

See table in chapter 6.3.

Options and accessories

All options available for the standard 30HXC units are compatible, except low-temperature option 5 for the evaporator available in the special unit.

ATTENTION: If units have two different operating modes - one with high condensing temperature and the other with low condensing temperature - and the transition is made with the unit in operation, the temperature must not vary by more than 3 K per minute. In cases where this is not possible, it is recommended to go through a unit start/stop switch (remote start/stop available for standard units).

6 - PHYSICAL AND ELECTRICAL DATA FOR UNITS 30GX

6.1 - Physical data 30GX

30GX		082	092	102	112	122	132	152	162	182	207	227	247	267	298	328	358	
Cooling capacity*	kW	276	297	321	377	407	438	496	527	603	691	750	810	921	988	1096	1217	
Operating weight	kg	3066	3097	3106	3350	3364	3378	3767	3783	4725	5520	5535	6121	6293	7339	7779	7950	
Refrigerant charge**	kg	HFC-134a																
Circuit A**		52	55	51	51	56	54	71	71	110	124	124	154	169	163	156	169	
Circuit B**		53	48	51	50	54	58	66	72	110	81	81	88	104	148	157	167	
Oil		Polyolester oil CARRIER SPEC. PP 47-32																
Circuit A	l	20	20	20	20	20	20	20	20	20	40	40	40	40	40	40	40	
Circuit B	l	20	20	20	20	20	20	20	20	20	20	20	20	20	40	40	40	
Compressors		Semi-hermetic, twin-screw POWER ³																
Circ. A - nom. size per compressor**		46	46	56	56	66	66	80	80	80+	66/56	80/66	80/80	80+/80+	80/80	80/80	80+/80+	
Circ. B. nom. size per compressor**		39	46	46	56	56	66	66	80	80+	80	80	80	80+	66/66	80/80	80+/80+	
Capacity control		PRO-DIALOG Plus control																
No. of control steps		6	6	6	6	6	6	6	6	6	8	8	8	8	10	10	10	
Minimum step capacity	%	19	21	19	21	19	21	19	21	21	16	14	14	14	9	10	10	
Evaporator		Shell and tube with internally finned copper tubes																
Net water volume	l	50	58	58	69	69	73	65	65	88	126	126	155	170	191	208	208	
Water connections		Victaulic connections																
Inlet/outlet	in	4	4	4	5	5	5	5	5	5	6	6	6	6	8	8	8	
Drain and vent (NPT)	in	3/8																
Max. water side operating pressure	kPa	1000																
Condensers		Copper tubes, aluminium fins																
Condenser fans		Axial FLYING BIRD 2 fan with a rotating shroud																
Quantity		4	4	4	6	6	6	8	8	8	10	10	12	12	14	16	16	
Fan speed	r/s	15.8																
Total air flow	l/s	19700	19700	19700	29550	29550	29550	39400	39400	39400	49250	49250	59100	59100	68950	78800	78800	

* Based on standardised ARI conditions: Evaporator entering/leaving water temperature 12.2°C and 6.7°C. Outdoor air temperature 35°C, evaporator fouling factor of 0.000022 m² K/W.

** The weights shown are guidelines only. For the unit refrigerant charge please refer to the unit nameplate.

6.2 - Electrical data 30GX

30GX		082	092	102	112	122	132	152	162	182	207	227	247	267	298	328	358	
Power circuit		The control circuit is supplied via the factory-installed transformer																
Nominal power supply	V-ph-Hz	380-3-60																
Voltage range	V	342-418																
Control circuit supply		The control circuit is supplied via the factory-installed transformer																
Nominal operating power input*	kW	91	99	113	121	142	163	172	186	208	234	267	278	313	353	378	425	
Nominal operating current drawn *	A	192	208	229	256	280	305	338	365	420	463	514	547	630	670	729	841	
Maximum power input**	kW	125	137	153	172	190	208	227	244	290	312	346	366	435	452	488	580	
Circuit A**	kW	-	-	-	-	-	-	-	-	190	224	244	290	244	244	290	290	
Circuit B**	kW	-	-	-	-	-	-	-	-	122	122	122	145	208	244	290	290	
Maximum operating current drawn (Un - 10%)***	A	239	260	289	325	358	391	428	459	545	588	651	689	818	850	918	1090	
Circuit A	A	-	-	-	-	-	-	-	-	358	421	459	545	459	459	545	545	
Circuit B	A	-	-	-	-	-	-	-	-	230	230	230	273	391	459	545	545	
Maximum operating current drawn (Un)***	A	217	237	263	295	325	355	389	417	496	534	592	626	744	772	834	992	
Circuit A	A	-	-	-	-	-	-	-	-	325	383	417	496	417	417	496	496	
Circuit B	A	-	-	-	-	-	-	-	-	209	209	209	248	355	417	496	496	
Maximum starting current, standard unit (Un)†	A	308	328	364	396	443	473	515	542	671	1272	1413	1447	1808	1594	1656	2055	
Circuit A†	A	-	-	-	-	-	-	-	-	-	1063	1204	1238	1560	1238	1238	1560	
Circuit B†	A	-	-	-	-	-	-	-	-	-	1030	1030	1030	1312	1093	1238	1560	
Max. starting current/max. current draw ratio, unit		1.42	1.38	1.38	1.34	1.36	1.33	1.32	1.30	1.35	2.38	2.39	2.31	2.43	2.06	1.98	2.07	
Max. starting current/max. current draw ratio, circuit A		-	-	-	-	-	-	-	-	-	3.27	3.14	2.97	3.15	2.97	2.97	3.15	
Max. starting current/max. current draw ratio, circuit B		-	-	-	-	-	-	-	-	-	4.94	4.94	4.94	5.29	3.08	2.97	3.15	
Max. starting current - reduced current start (Un)†	A	std.	std.	std.	std.	std.	std.	std.	std.	std.	816	906	940	1109	1087	1149	1356	
Circuit A	A	std.	std.	std.	std.	std.	std.	std.	std.	std.	607	697	731	861	731	731	861	
Circuit B	A	std.	std.	std.	std.	std.	std.	std.	std.	std.	373	373	373	463	637	731	861	
Max. starting current - red. current start/max. current draw ratio, unit		std.	std.	std.	std.	std.	std.	std.	std.	std.	1.53	1.53	1.50	1.49	1.41	1.38	1.37	
Circuit A		std.	std.	std.	std.	std.	std.	std.	std.	std.	1.87	1.82	1.75	1.74	1.75	1.75	1.74	
Circuit B		std.	std.	std.	std.	std.	std.	std.	std.	std.	1.79	1.79	1.79	1.87	1.79	1.75	1.74	
Three-phase short-circuit holding current	kA	25	25	25	25	25	25	25	25	25	N/A	N/A	N/A	N/A	N/A	N/A	N/A	
Circuit A	kA	-	-	-	-	-	-	-	-	-	25	25	25	25	25	25	25	
Circuit B	kA	-	-	-	-	-	-	-	-	-	25	25	25	25	25	25	25	
Standby capacity, unit or circuit A		for evaporator water pump connections‡																
	kW	4	4	4	5.5	5.5	5.5	7.5	7.5	7.5	7.5	9	9	9	15	15	15	

* Based on standardised ARI conditions: Evaporator entering/leaving water temperature 12.2°C and 6.7°C. Outdoor air temperature 35°C.

** Power input, compressor and fan, at unit operating limits (evaporator water entering/leaving temperature = 15°C/10°C, outdoor air temperature = 46°C) and a nominal voltage of 380 V (data given on the unit name plate).

*** Maximum unit operating current at maximum unit power input.

† Maximum instantaneous starting current (maximum operating current of the smallest compressor(s) + fan current + locked rotor current or reduced starting current of the largest compressor).

‡ Current and power inputs not included in the values above

N/A Not applicable

6.3 - Electrical data, 30GX and 30HXC compressors, option 150 + 150A

Reference	Size	I nom.	MHA	LRA	LRA (Y)	LRA (S) 1 cp.	LRA (S) 2 cp.
06NA2123W6N	39	62	84	485	153	NA	NA
06NA2146W7N	46	73	102	580	183	NA	NA
06NA2174W7N	56	89	125	685	216	245	345
06NA2209W7N	66	107	153	820	259	290	410
06NA2250W7N	80	127	178	920	291	320	460
06NA2250W7E	80+	148	214	1175	371	405	535

Legend:

- 06NA - Compressor for air-cooled units
- N - Non-economized compressor
- E - Economized compressor
- INOM - Average current draw of the compressor at ARI conditions
- MHA - Must hold amperes (maximum operating current) at 342 V
- LRA - Locked rotor current with across-the-line start
- LRA (Y) - Locked rotor current at reduced current (star/delta start-up mode)
- LRA (S) 1 cp. - Start-up with reduced current with electronic starter (start-up duration 3 seconds max.) for one compressor per circuit
- LRA (S) 2 cp. - Start-up with reduced current with electronic starter (start-up duration 3 seconds max.) for two compressors per circuit

8 - ELECTRICAL CONNECTION

8.5 - Recommended wire sections

Wire sizing is the responsibility of the installer, and depends on the characteristics and regulations applicable to each installation site. The following is only to be used as a guideline, and does not make Carrier in any way liable. After wire sizing has been completed, using the certified dimensional drawing, the installer must ensure easy connection and define any modifications necessary on site.

The connections provided as standard for the field-supplied power entry cables to the general disconnect/isolator switch are designed for the number and type of wires, listed in the tables that follow.

The calculations are based on the maximum machine current (see electrical data tables).

For the design the following standardised installation methods are used, in accordance with IEC 60364, table 52C:

- For 30HXC units installed inside the building: No.13: perforated horizontal cable conduit, and No. 41: closed conduit.
- For 30GX units installed outside the building: No.17: suspended aerial lines, and No. 61: buried conduit with a derating coefficient of 20.

The calculation is based on PVC orXLPE insulated cables with copper or aluminium core. The maximum temperature is 40°C for 30HXC units and 46°C for 30GX units.

The given wire length limits the voltage drop to < 5%.

IMPORTANT: Before connection of the main power cables (L1 - L2 - L3) on the terminal block, it is imperative to check the correct order of the 3 phases before proceeding to the connection on then terminal block or the main disconnect/ isolator switch.

8.5.1 - Field control wiring

Refer to the 30GX/HXC Pro-Dialog Plus Controls IOM and the certified wiring diagram supplied with the unit for the field control wirting of the following features:

- Evaporator pump interlock (mandatory)
- Remote on/off switch
- Condenser flow switch (field-supplied, 30HXC only)
- Remote heat/cool switch
- Demand limit external switch 1
- Remote dual set point
- Alarm report by circuit
- Evaporator pump control
- Condenser pump control (30HXC only)
- Remote set point reset or outside air temperature sensor reset (0-10 V)

8.5.2 - Selection table of minimum and maximum wire sections for connection to 30HXC units

380 V-3 ph-60 Hz

30HXC	Minimum wire section (mm ²)	Wire type	L (m)	Maximum wire section (mm ²)	Wire type	L (m)
080	1 x 50	XLPE Cu	160	1 x 120	XLPE Al	205
090	1 x 50	XLPE Cu	160	1 x 120	XLPE Al	205
100	1 x 70	XLPE Cu	170	1 x 150	XLPE Al	210
110	1 x 70	XLPE Cu	170	1 x 150	XLPE Al	210
120	1 x 70	XLPE Cu	170	1 x 185	XLPE Al	220
130	1 x 95	XLPE Cu	180	1 x 240	XLPE Al	225
140	1 x 120	XLPE Cu	185	1 x 240	XLPE Al	225
155	1 x 120	XLPE Cu	185	2 x 95	XLPE Al	195
175	1 x 120	XLPE Cu	185	2 x 120	XLPE Al	205
190	1 x 150	XLPE Cu	190	2 x 120	XLPE Al	205
200 Circuit A	1 x 70	XLPE Cu	170	1 x 185	XLPE Al	220
				1 x 120	XLPE Cu	225
230 Circuit A	1 x 95	XLPE Cu	180	1 x 240	XLPE Al	225
				1 x 150	XLPE Cu	230
260 Circuit A	1 x 120	XLPE Cu	185	2 x 120	XLPE Al	255
				1 x 185	XLPE Cu	235
285 Circuit A	1 x 120	XLPE Cu	185	2 x 150	XLPE Al	265
				1 x 185	XLPE Cu	235
310 Circuit A	1 x 95	XLPE Cu	180	1 x 240	XLPE Al	225
				1 x 150	XLPE Cu	230
345 Circuit A	1 x 120	XLPE Cu	185	2 x 120	XLPE Al	255
				1 x 185	XLPE Cu	235
375 Circuit A	1 x 120	XLPE Cu	185	2 x 150	XLPE Al	265
				1 x 185	XLPE Cu	235
200 Circuit B	1 x 50	XLPE Cu	160	1 x 120	XLPE Al	205
				1 x 70	XLPE Cu	205
230 Circuit B	1 x 70	XLPE Cu	170	1 x 150	XLPE Al	210
				1 x 95	XLPE Cu	215
260 Circuit A	1 x 70	XLPE Cu	170	1 x 150	XLPE Al	210
				1 x 95	XLPE Cu	215
285 Circuit A	1 x 70	XLPE Cu	170	1 x 185	XLPE Al	220
				1 x 150	XLPE Cu	225
310 Circuit A	1 x 150	XLPE Cu	190	2 x 150	XLPE Al	265
				1 x 240	XLPE Cu	235
345 Circuit A	1 x 150	XLPE Cu	190	2 x 185	XLPE Al	270
				2 x 120	XLPE Cu	280
375 Circuit A	1 x 185	XLPE Cu	190	2 x 185	XLPE Al	270
				2 x 120	XLPE Cu	280

S Power supply wire section (see diagram in chapter 'Electrical connection').

8.5.3 - Selection table of minimum and maximum wire sections for connection to 30HXC units with high condensing temperatures (option 150 + 150A)

380 V-3 ph-60 Hz

30HXC	Minimum wire section (mm²)	Wire type	L (m)	Maximum wire section (mm²)	Wire type	L (m)
080	1 x 70	XLPE Cu	170	1 x 185	XLPE Al	220
090	1 x 95	XLPE Cu	180	1 x 240	XLPE Al	225
100	1 x 95	XLPE Cu	180	1 x 240	XLPE Al	225
110	1 x 120	XLPE Cu	185	2 x 95	XLPE Al	195
120	1 x 120	XLPE Cu	185	2 x 120	XLPE Al	205
130	1 x 150	XLPE Cu	190	2 x 120	XLPE Al	205
140	1 x 185	XLPE Cu	190	2 x 150	XLPE Al	210
155	1 x 240	XLPE Cu	190	2 x 185	XLPE Al	220
175	1 x 240	XLPE Cu	190	2 x 185	XLPE Al	220
190	2 x 95	XLPE Cu	170	2 x 240	XLPE Al	225
200 Circuit A	1 x 120	XLPE Cu	185	2 x 150	XLPE Al	265
				1 x 240	XLPE Cu	235
230 Circuit A	1 x 150	XLPE Cu	190	2 x 185	XLPE Al	270
				1 x 240	XLPE Cu	235
260 Circuit A	1 x 240	XLPE Cu	190	2 x 240	XLPE Al	280
				2 x 150	XLPE Cu	290
285 Circuit A	1 x 240	XLPE Cu	190	2 x 240	XLPE Cu	295
310 Circuit A	1 x 185	XLPE Cu	190	2 x 240	XLPE Al	280
				2 x 150	XLPE Cu	290
345 Circuit A	1 x 240	XLPE Cu	190	2 x 240	XLPE Al	280
				2 x 150	XLPE Cu	290
375 Circuit A	1 x 240	XLPE Cu	190	2 x 240	XLPE Cu	295
200 Circuit B	1 x 70	XLPE Cu	170	1 x 150	XLPE Al	210
				1 x 120	XLPE Cu	225
230 Circuit B	1 x 95	XLPE Cu	180	1 x 240	XLPE Al	225
				1 x 150	XLPE Cu	230
260 Circuit B	1 x 95	XLPE Cu	180	1 x 240	XLPE Al	225
				1 x 150	XLPE Cu	230
285 Circuit B	1 x 120	XLPE Cu	185	2 x 150	XLPE Al	265
				1 x 185	XLPE Cu	235
310 Circuit B	1 x 240	XLPE Cu	190	2 x 240	XLPE Cu	295
345 Circuit B	2 x 95	XLPE Cu	170	2 x 240	XLPE Cu	295
375 Circuit B	1 x 240	XLPE Cu	190	2 x 240	XLPE Cu	295

S Power supply wire section (see diagram in chapter 'Electrical connection').

8.5.4 - Selection table of minimum and maximum wire sections for connection to 30GX units

380 V-3 ph-60 Hz

30GX	Minimum wire section (mm ²)	Wire type	L (m)	Maximum wire section (mm ²)	Wire type	L (m)
082	1 x 95	XLPE Cu	190	2 x 240	PVC Al	450
092	1 x 120	XLPE Cu	200	2 x 240	PVC Al	450
102	1 x 120	XLPE Cu	200	2 x 185	PVC Cu	470
112	1 x 150	XLPE Cu	200	2 x 240	PVC Cu	480
122	1 x 185	XLPE Cu	205	2 x 240	XLPE Cu	355
132	1 x 240	XLPE Cu	205	3 x 240	PVC Cu	600
152	1 x 240	XLPE Cu	205	3 x 185	XLPE Cu	430
162	2 x 95	XLPE Cu	190	3 x 185	XLPE Cu	430
182	2 x 120	XLPE Cu	200	3 x 240	XLPE Cu	440
207 Circuit A	1 x 185	XLPE Cu	205	2 x 240	XLPE Cu	440
				3 x 240	PVC Cu	685
227 Circuit A	1 x 240	XLPE Cu	205	3 x 240	XLPE Cu	505
247 Circuit A	2 x 95	XLPE Cu	190	3 x 240	XLPE Cu	505
267 Circuit A	2 x 120	XLPE Cu	200	3 x 240	XLPE Cu	505
298 Circuit A	2 x 95	XLPE Cu	190	3 x 240	XLPE Cu	505
328 Circuit A	2 x 95	XLPE Cu	190	3 x 240	XLPE Cu	505
358 Circuit A	2 x 120	XLPE Cu	200	3 x 240	XLPE Cu	505
207 Circuit B	1 x 95	XLPE Cu	190	2 x 150	XLPE Al	375
				2 x 185	PVC Cu	590
				1 x 240	XLPE Cu	355
227 Circuit B	1 x 95	XLPE Cu	190	2 x 150	XLPE Al	375
				1 x 240	XLPE Cu	355
247 Circuit B	1 x 95	XLPE Cu	190	2 x 150	XLPE Al	375
				1 x 240	XLPE Cu	355
267 Circuit B	1 x 120	XLPE Cu	200	2 x 240	XLPE Al	410
				2 x 120	XLPE Cu	400
298 Circuit B	1 x 185	XLPE Cu	205	3 x 150	XLPE Cu	475
				3 x 240	XLPE Al	470
328 Circuit B	1 x 240	XLPE Cu	205	3 x 240	XLPE Cu	505
358 Circuit B	2 x 95	XLPE Cu	190	3 x 240	XLPE Cu	505

S Power supply wire section (see diagram in chapter 'Electrical connection').



Order No: 13404-76, 11.2000 - Supersedes order No: New
 Manufacturer reserves the right to change any product specifications without notice.

Manufacturer: Carrier s.a., Montluel, France.
 Printed in the Netherlands on chlorine-free paper.



Environmental Management System Approval